

# Quick Start Guide

Ages 8+



Hi, I'm mBot, your new robot friend. I look forward to learning with you all along.

Let me introduce myself. I'm a programmable educational robot used for STEAM education, and a member of the Maker's Platform of Makeblock. I can be assembled easily and quickly using only one screwdriver. Together with Makeblock software, Makeblock App and mBlock, I can help you to learn programming from the beginning stages to the advanced stages.

Now, let's begin our journey in the world of robotics together.

D1.1.L\_KD010087000



1

## Assembling the mBot

Follow the steps in the Assembling Manual to transform parts into mBot.

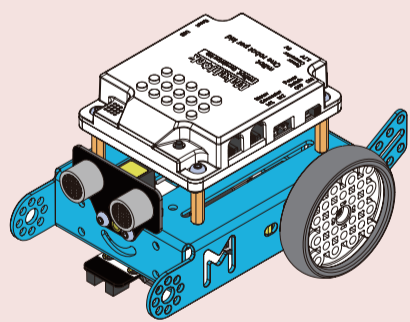
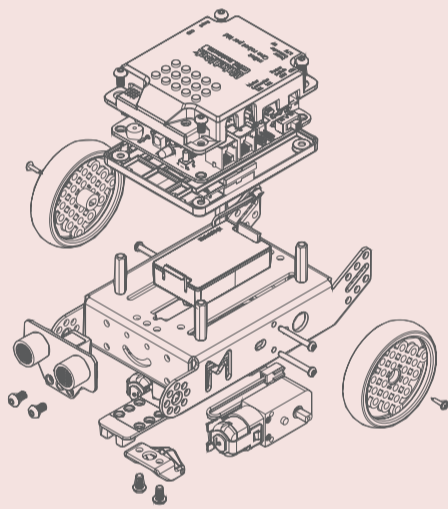

2

## Play with mBot

mBot has three preset modes: infrared remote control mode (default), obstacle avoidance mode, and line-following mode. Switch modes using the **infrared remote controller** or the **on-board button**. Start mBot now and enjoy!

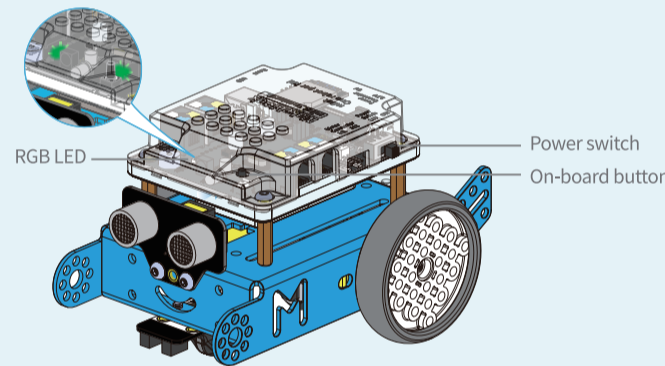

**How to recognize the current mode?**  
The color of the LED on the main board indicates the mode.

- White: infrared remote control mode
- Green: obstacle avoidance mode
- Blue: line following mode



### Obstacle avoidance mode

In obstacle avoidance mode, mBot moves and avoids obstacles autonomously.

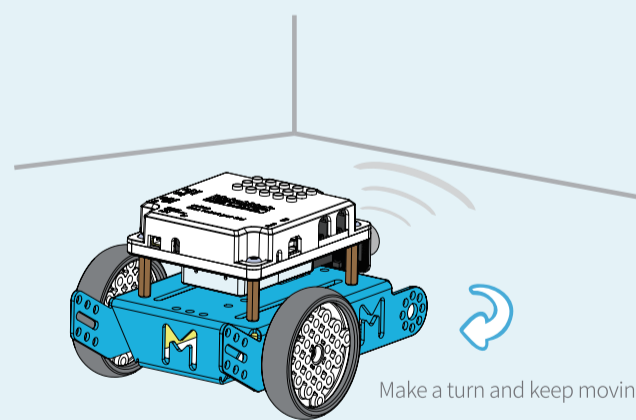

With the help of the ultrasonic sensor, mBot can detect the distance of itself to an object in front of it.



### Infrared remote control mode

A special infrared remote controller is included in the box. You can use the controller to change the speed, direction and other behaviors of the mBot. A smooth and flat playground is recommended.

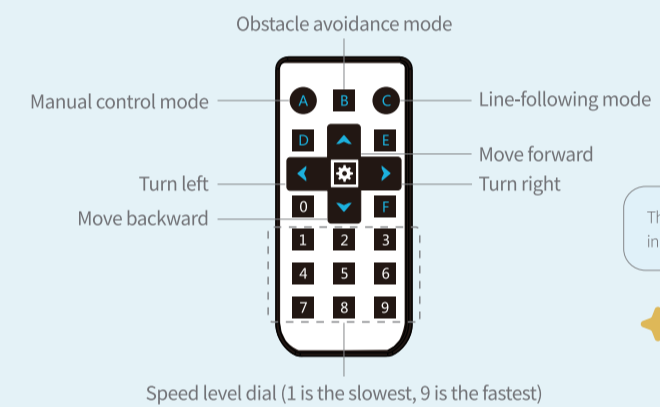

The direction can only be changed in the manual control mode.



### Line following mode

In line following mode, mBot moves autonomously along black lines on the map.

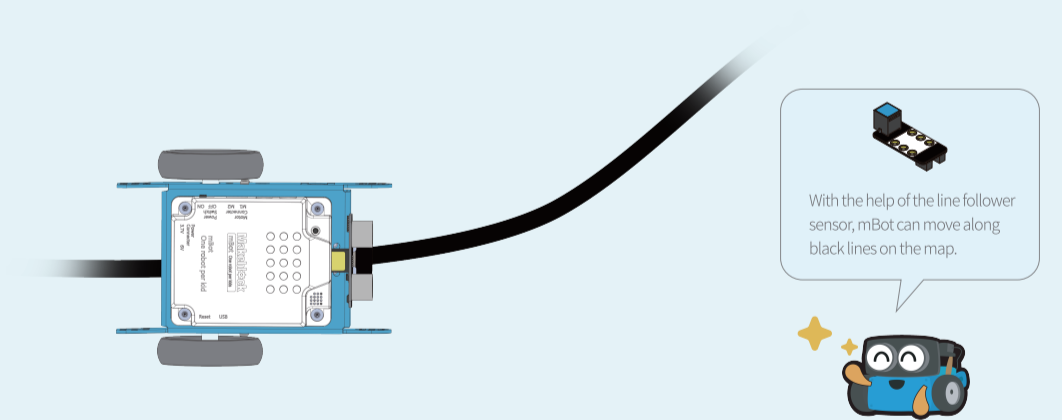

With the help of the line follower sensor, mBot can move along black lines on the map.



3

## Control mBot with the Makeblock App

Makeblock App is the advanced controller of Makeblock robots. It can control mBot to dance and sing for example.

### Getting started?

1. Search "Makeblock" in the application store, to download and install the Makeblock app.



2. Open the app and start to experience the different features with mBot!

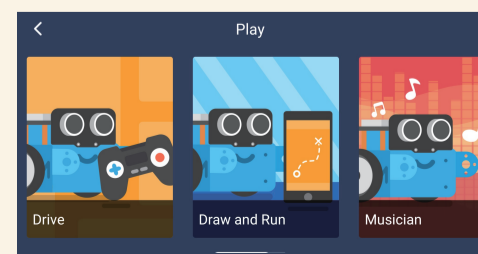

4

## Programming for beginners -- mBlock Blockly App

mBlock Blockly App is a game based learning app for beginners to learn programming. The interactive tasks make learning a fun and progressive experience.

### Getting started?

1. Search "mBlock Blockly" in the application store, to download and install the mBlock Blockly app.

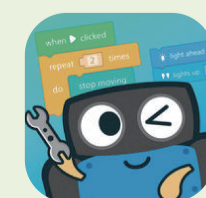

2. Open the app and start to crack the tasks with mBot!

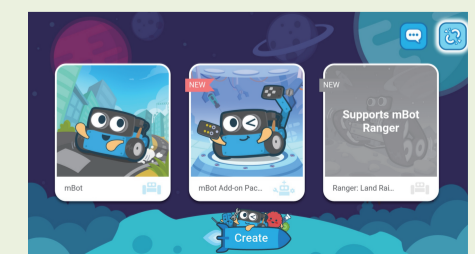

## Advancing your programming -- mBlock 5

mBlock 5 is a learning platform to learn programming. It integrates block based programming language and real-time translation to other advanced programming languages. Children can learn programming from a beginner level to an advanced level.

Download: <http://www.mblock.cc/>

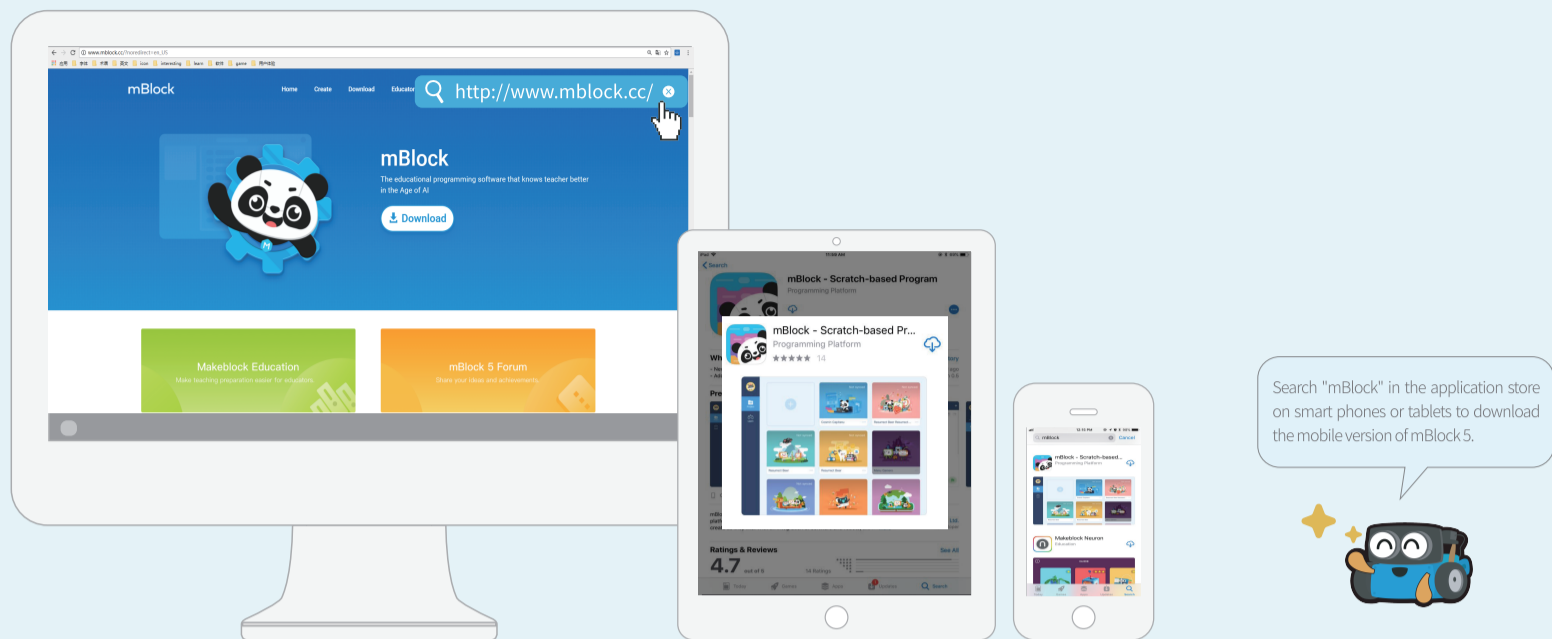

After installation, the programming learning journey will begin!

### 1. Start mBot

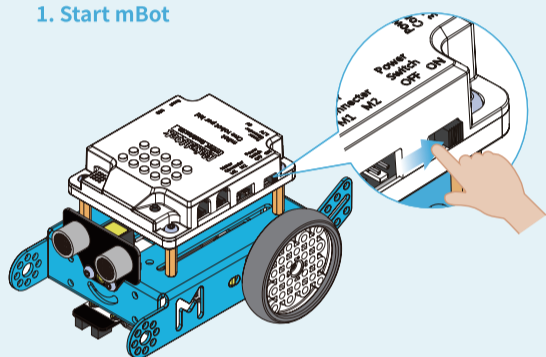

### 2. Connect mBot to the computer.

Method 1: Connect mBot to a computer via the USB cable.

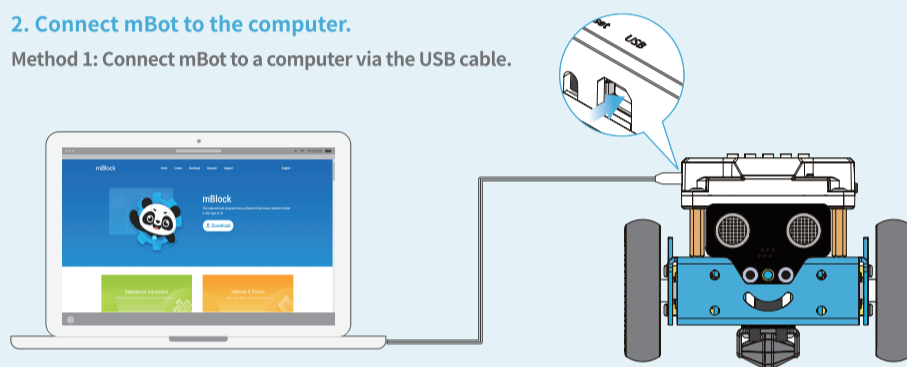

Method 2: Connect mBot to a computer via the Makeblock Bluetooth Dongle (this dongle is only included in the Bluetooth Dongle version).

- 1 Insert the Makeblock Bluetooth Dongle in a USB port of the computer.
- 2 Press **3**, the blue LED indicator will blink rapidly, which means the dongle is searching for a device.
- 3 Put mBot close to the dongle, and they will automatically pair with each other. The LED indicator stops blinking and stays on when they have successfully paired.

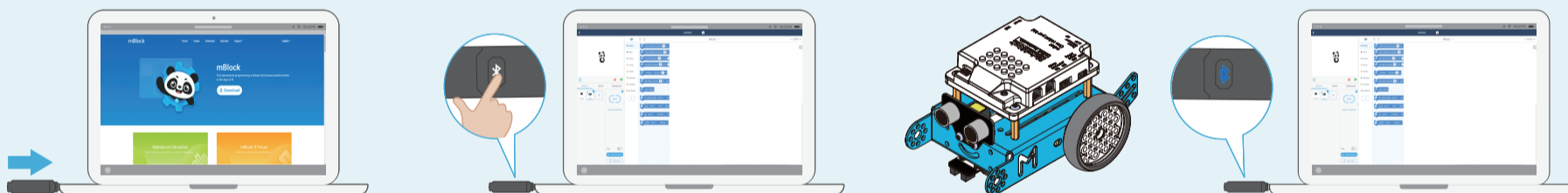

### 3. Begin programming!

- 1 Start mBlock 5 and add mBot from the Devices Library.
- 2 Click "Connect" to activate the connection panel.
- 3 Start programming with mBlock 5. There is a Beginner's Guide available under "Help" in the menu list.
- 4 Upload your program to mBot.

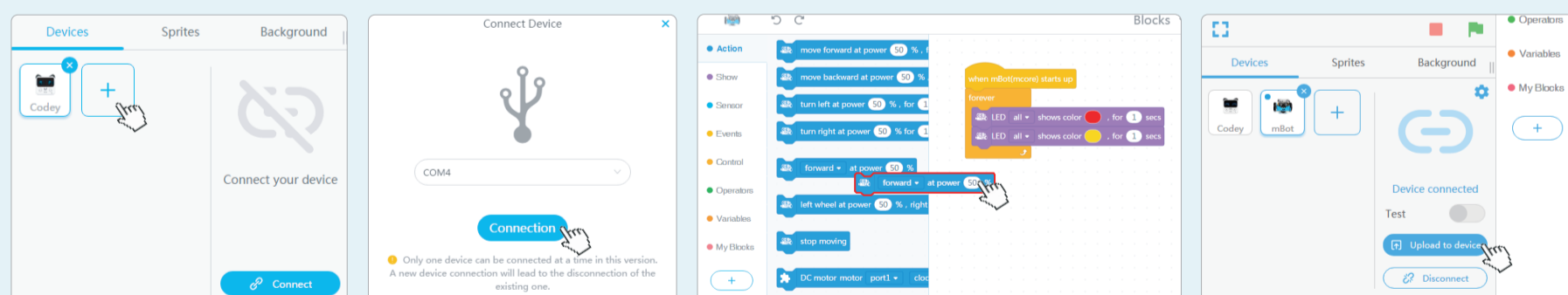

Note: Some details of the user interface of mBlock 5 may change due to different versions.

## Expand mBot

You can add a variety of extensions and components to mBot. With these extensions, mBot can be transformed into a dancing cat, a crazy frog and so on.

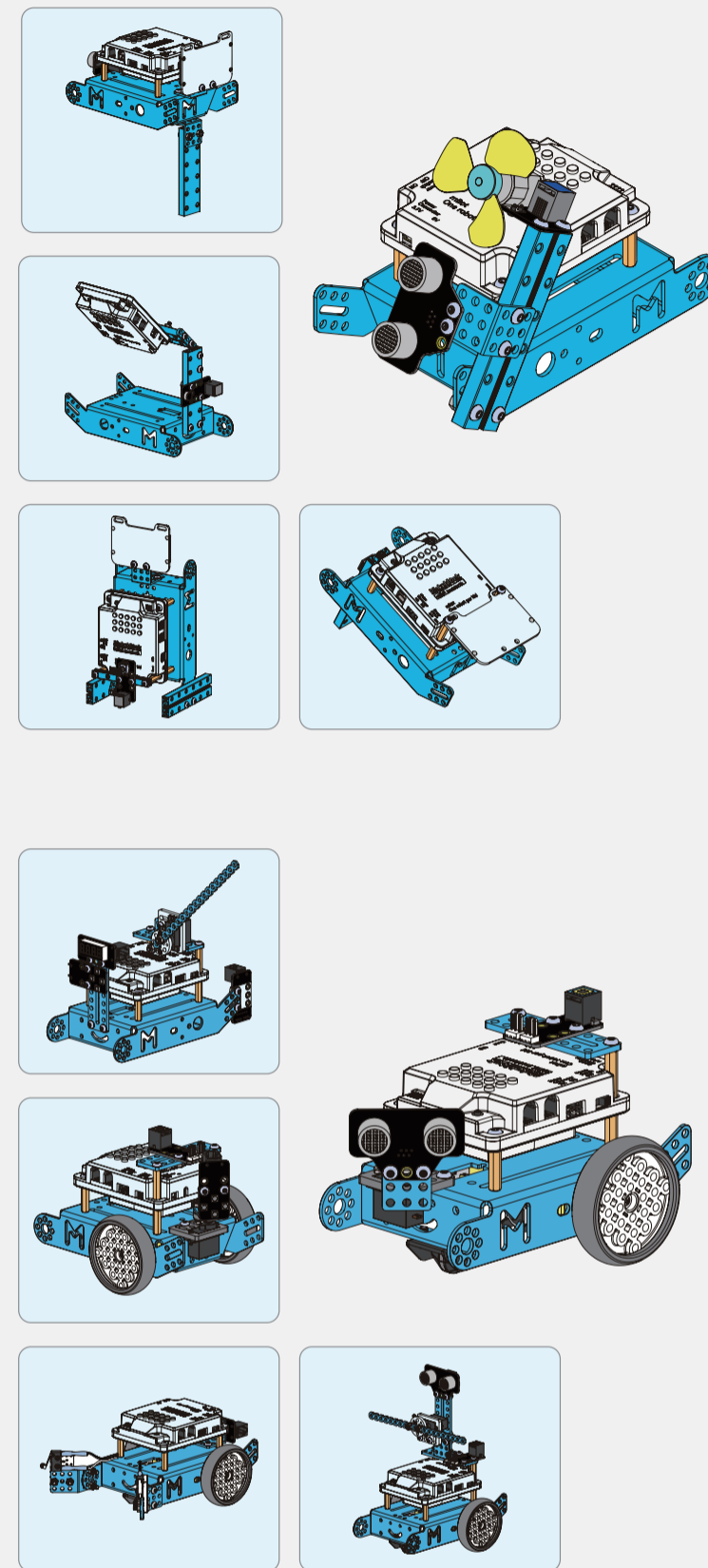

For more information, please visit:  
<http://learn.makeblock.com/en/mbot-add-on-packs/>

## FAQ

### The Forwards and Backwards controls are reversed when I control mBot to move. What's the problem?

This may be caused by the cables of the motor being incorrectly connected to the control board. Swap the motor cables ports (M1 and M2) and try again.

### Why is the mBot not responding to the infrared remote controller?

1. Check whether the batteries are inserted correctly into the infrared remote controller.
2. Make sure the preset program of the mBot is in the infrared remote control mode. Check the on-board LEDs' color. If they are not in white, press the on-board button to switch to infrared remote control mode.
3. The infrared remote controller can only be used for the default programs. If a customized program is uploaded to mBot, the infrared remote controller will no longer work. Reset the default programs of the mBot using mBlock on PC/Mac.

### Why doesn't mBot follow the route when I control mBot to go straight?

1. The tire(s) may be in contact with the RJ25 cables or the motor cables, which causes the wheel(s) to slightly jam. Please check the cables and reorganize them.
2. This can be caused by the low battery. Please charge or change the batteries.

### Why doesn't mBot avoid obstacles in obstacle avoidance mode?

1. Check the connectivity of the ultrasonic module and the control board. Make sure the ultrasonic sensor is connected to the port 3 on the board.
2. Check whether the indicator is solid red or not. If it's not, it means the cable might be loose. Please check the connectivity once again.
3. In the preset program, the on-board LED can indicate the modes. Make sure the on-board LEDs are green. You can press the on-board button to switch modes.

To check more FAQs, please visit:  
<https://forum.makeblock.com/>

